



X-TYPE

DATE 02/04

XT501-S948

SERVICE

TECHNICAL BULLETIN

Front Seat Stabilization Kit –
Change Of Specification –
Service Action S948

MODEL 2002-03 MY
X-TYPE
VIN C00294-D19415

Issue:

Technical Service Bulletin XT501-03 was issued in April 2002 to provide a service fix to improve the linkage free-play condition on front seats, generally described as ‘seat rock’. In November 2003, Technical Bulletin XT501-03 was amended to instruct dealers not to install the seat stabilization kit to any vehicle.

The Technical Bulletin was rescinded following concerns that the spring housing can become disengaged from the seat frame. Investigations have concluded that this is caused by the maximum distance between the seat rods exceeding the capability of the assembly.

Action:

Check all vehicle history records, warranty history records and DDW for the vehicles that have had the seat stabilization kit installed (part number: C2S 20272). A revised kit that has been designed to cope with a wider range of track rod center distances must be fitted to those vehicles identified.

Note: Only those vehicles previously fitted with part number C2S 20272 require the rework under this Service Action.

This repair must be performed at the next available opportunity.

Warning: Under no circumstances should part number C2S 20272 be fitted to any more vehicles.

NOTE: The information in Technical Bulletins is intended for use by trained, professional technicians with the knowledge, tools, and equipment to do the job properly and safely. It informs these technicians of conditions that may occur on some vehicles, or provides information that could assist in proper vehicle service. The procedures should not be performed by “do-it-yourselfers.” Do not assume that a condition described affects your car. Contact a Jaguar retailer to determine whether the Bulletin applies to your vehicle.

WORKSHOP PROCEDURE

1. Check under seats to confirm the presence of spring unit without 'AB' markings.
See Illustration 1.

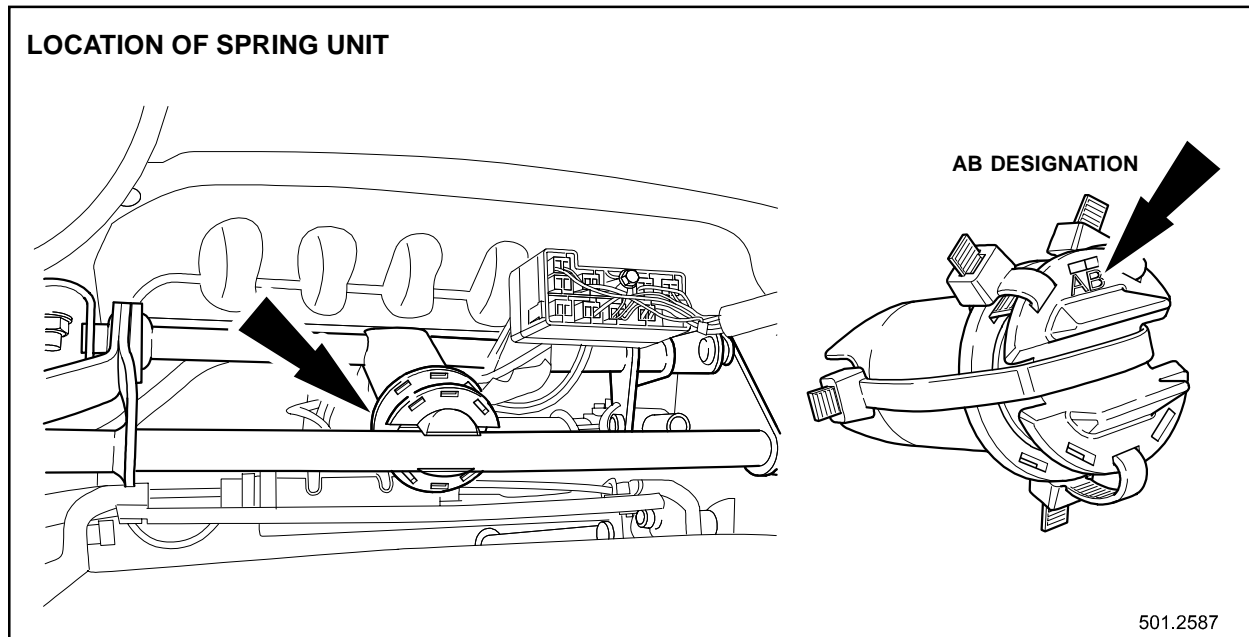

ILLUSTRATION 1

⚠ Warning: Do not cut the three black tie straps from the spring unit until it is compressed into position in the vehicle.

2. Record vehicle identification number for administration purposes.
3. Start engine to prevent battery drain
4. Reposition seat fully rearwards.
5. Reposition seat cushion rear fully upward.
6. Reposition seat cushion front fully downward (to fully compress the spring unit).
7. Install and secure two black tie straps, provided with new parts, to front outer slots of spring unit.
8. Reposition seat cushion front fully upward to allow spring unit to expand against the tie straps.

9. Remove spring unit from seat frame front upper and lower cross tubes by twisting 45 degrees sideways.
10. Install remaining black tie strap provided with new parts to center slots on opposite side of spring unit to other two.
11. Install red tie strap provided with new parts around body of spring unit (Illustration 2).
12. Cut, remove and discard protruding tails from the four tie straps.

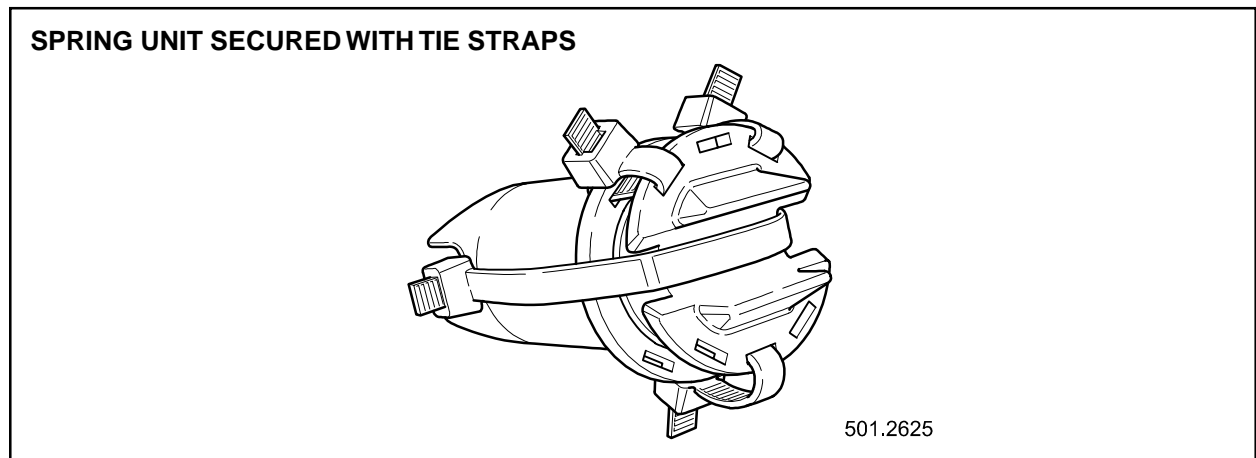

ILLUSTRATION 2

13. Place new spring unit, provided, (with 'AB' marking, see Illustration 3) to front.

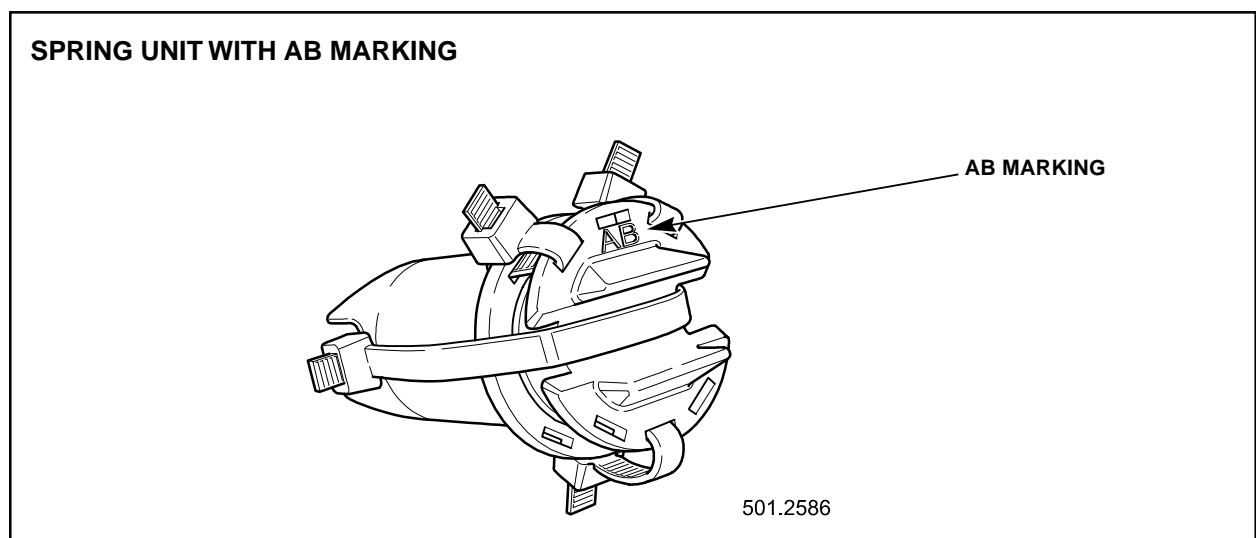

ILLUSTRATION 3

14. Cut, remove and discard red tie strap only from spring unit.

15. Install spring unit to seat frame front upper and lower cross tubes. Spring unit to be inserted at 45 degrees. Engage upper tube first and twist sideways to engage lower tube.

Note: Position the spring unit on the center-line of the seat with two fitted tie straps to the front.

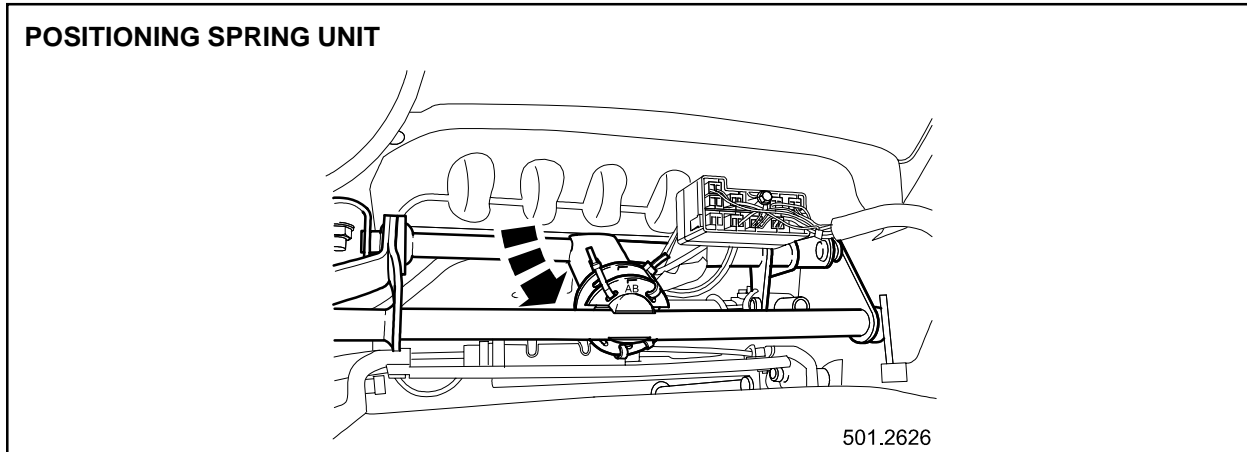

ILLUSTRATION 4

16. Reposition the seat cushion front fully downwards to fully compress the spring unit.

Note: Ensure spring unit is fully compressed with its end jaws fully engaged on the seat frame tubes.

17. Cut, remove and discard the remaining three tie straps from the spring unit (Illustration 5.)

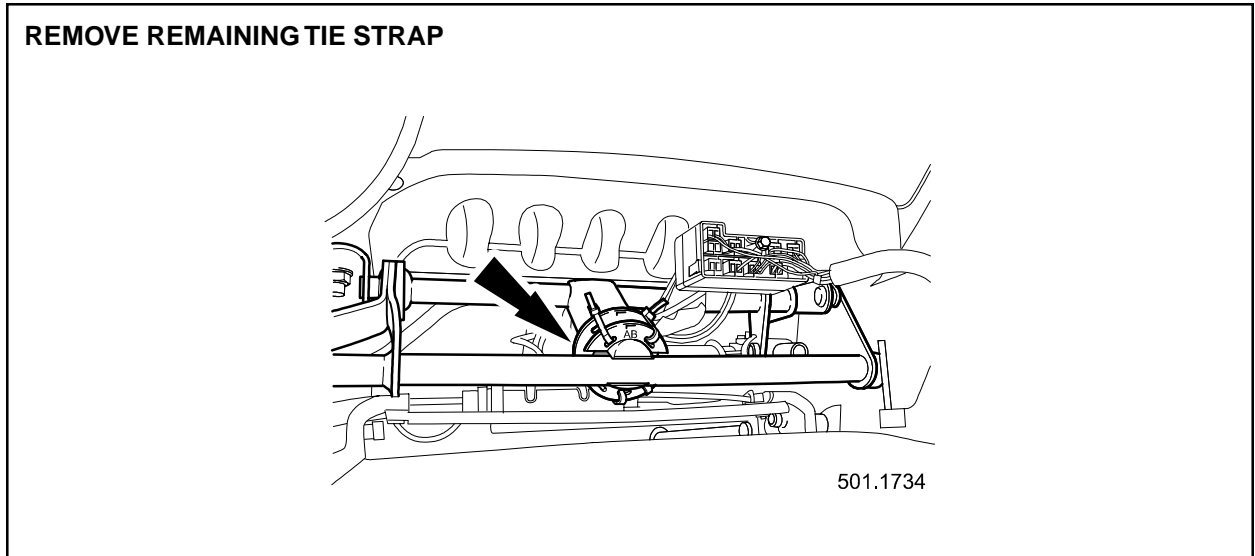

ILLUSTRATION 5

18. Reposition the front seat to the original position.

Note: If non 'AB' spring units were fitted to both front seats, carry out steps 4 to 18 on the second seat.

19. Turn off engine.
20. Close door.

Parts Information:

DESCRIPTION
Seat spring kit

PART NUMBER
C2S 35849

QTY
1 or 2

Warranty Information:

Warranty claims should be submitted quoting program code S948 together with option code X and the parts and SROs from the table below.

This will result in payment of the stated time and, where applicable the relevant parts/ miscellaneous expense codes.

The options that allow for drive in/drive out can only be claimed when the vehicle has been brought into the workshop for this action alone to be undertaken.

Service Action S948

2002 MY 2.5L VIN Range **2XC00294 - 2XC86114**
 2002 MY 3.0L VIN Range **2WC00294 - 2WC86114**
 2003 MY 2.5L VIN Range **3XC86115 - 3XD19415**
 2003 MY 3.0L VIN Range **3WC86115 - 3WD19415**

| Program Code | Option | Description | SRO | Time | Part Number | Part Description | Qty |
|--------------|--------|---|-------------|----------|-------------|------------------|--------|
| S948 | X | Replace seat spring kit – one side only | 76.94.38 | 0.2 hrs. | C2S 35849 | Seat spring kit | 1 or 2 |
| S948 | X | Replace seat spring kit – both sides | 76.94.38/01 | 0.2 hrs. | C2S 35849 | Seat spring kit | 1 or 2 |
| | | Drive in/drive out | 10.10.10 | 0.1 hrs. | | | |

NOTE: Always perform a DDW claim search first to determine whether this service action has been performed on this vehicle. The “Review Claim History” function will provide a listing of all claims against the vehicle. If this service action number appears in the program code field, do not perform this service action.

